

Half Gallon - Industrial

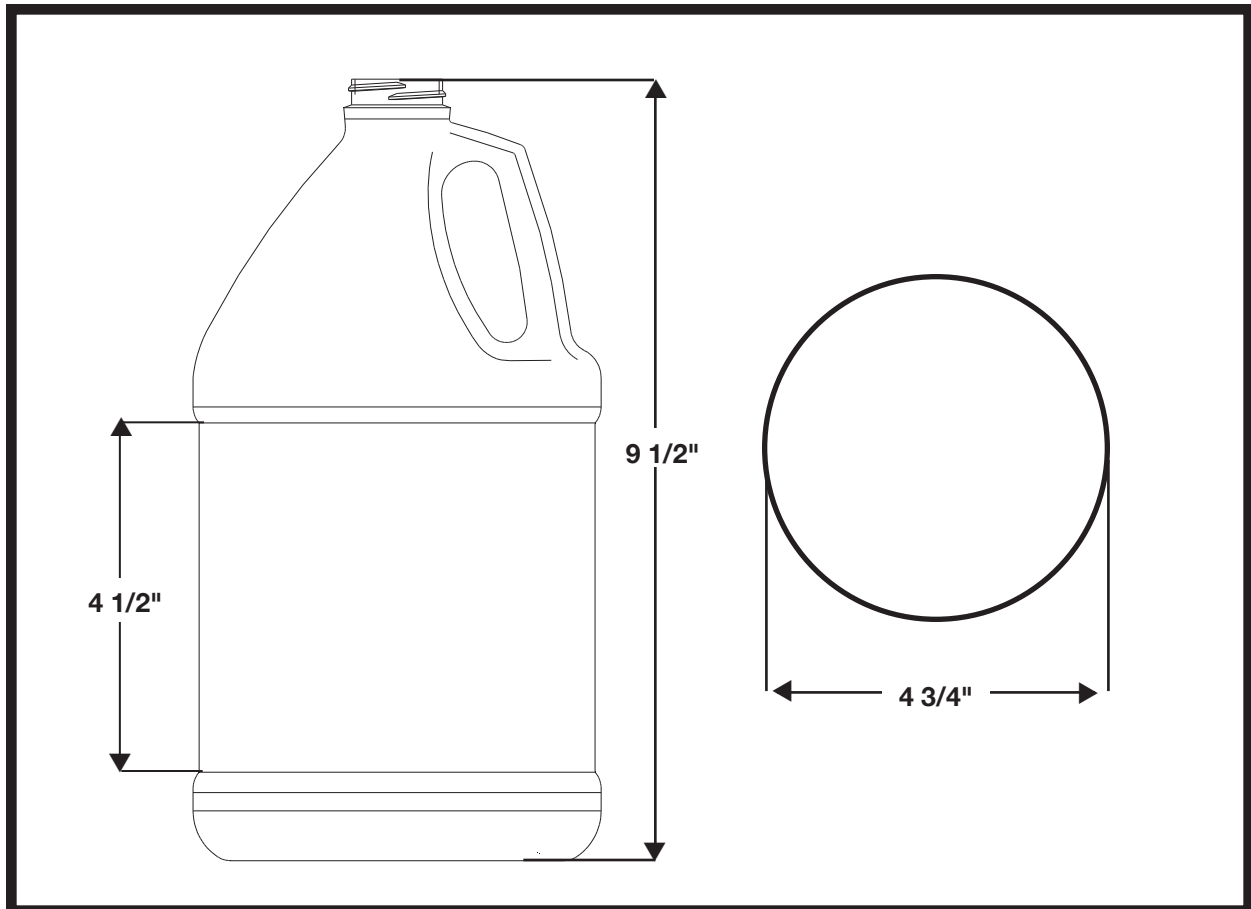

MATERIAL: HDPE

NECK FINISH: 38-400

WEIGHT: 70-120 GRAMS

BOTTLE HEIGHT: 9 1/2"

PANEL HEIGHT: 4 1/2"

DIAMETER: 4 3/4"

CAPACITY: 64 Oz.



SILKSCREEN DIMENSIONS:

4 " Height X 13 1/2" Width

CASE PACK: Bulk - 60 Ea. @6/1

UNIT PACK: Bulk - 360 EA.
6/1@ 360 Ea.