



PARAGON PACKAGING INC.

1-800-899-1010

WWW.PARAGON-PACKAGING.COM

16 Ounce Ring Neck Carafe

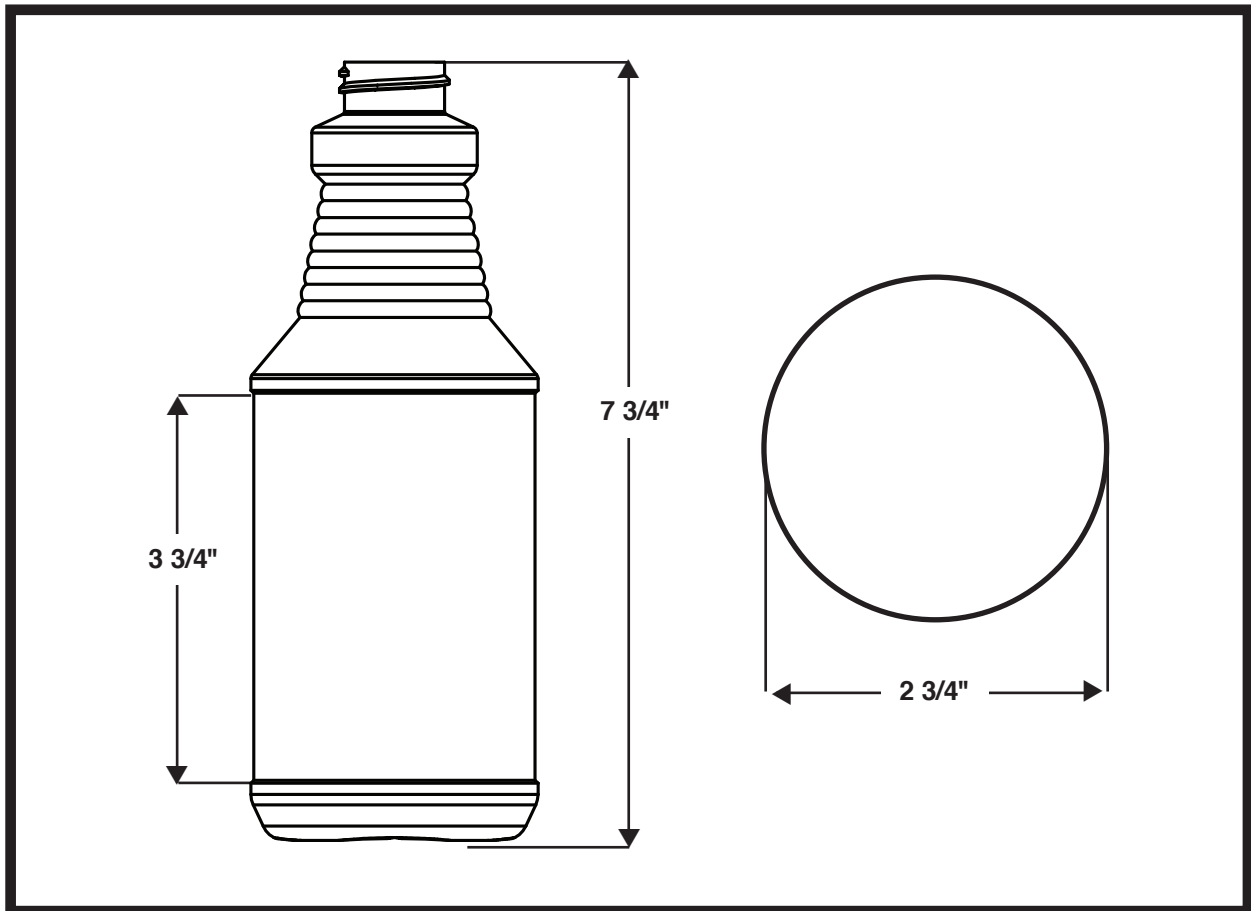

MATERIAL: HDPE

NECK FINISH: 28-400

WEIGHT: 30 GRAMS

BOTTLE HEIGHT: 7 3/4"

PANEL HEIGHT: 3 3/4"

DIAMETER: 2 3/4"

CAPACITY: 16 OUNCES



SILKSCREEN DIMENSIONS:

8" Width x 3 1/4" Height

CASE PACK: 150 Ea.

UNIT PACK: 2400 EA.