



**PARAGON PACKAGING INC.**

**1-800-899-1010**

**WWW.PARAGON-PACKAGING.COM**

## 2 Ounce Cylinder

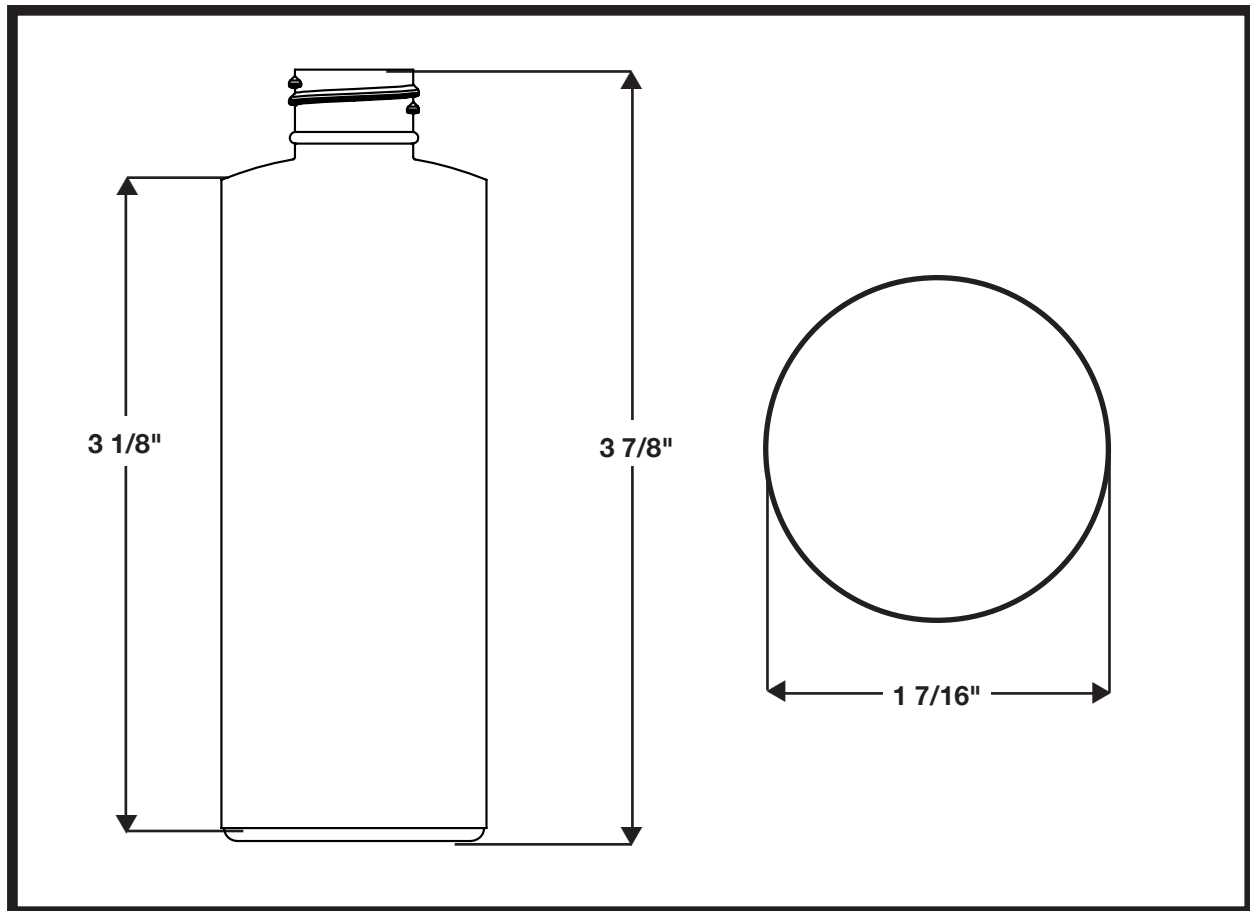

**MATERIAL:** HDPE

**NECK FINISH:** 24-410

**NOMINAL WEIGHT:** 10 GRAMS

**BOTTLE HEIGHT:** 3 7/8"

**PANEL HEIGHT:** 3 1/8"

**DIAMETER:** 1 7/16"

**CAPACITY:** 2 OUNCES



**SILKSCREEN DIMENSIONS:**

3.5" Width x 2.5" Height

**CASE PACK, BULK:** 1,258 Ea.

**UNIT PACK, BULK:** 20,128 Ea.