

16 Ounce Cylinder

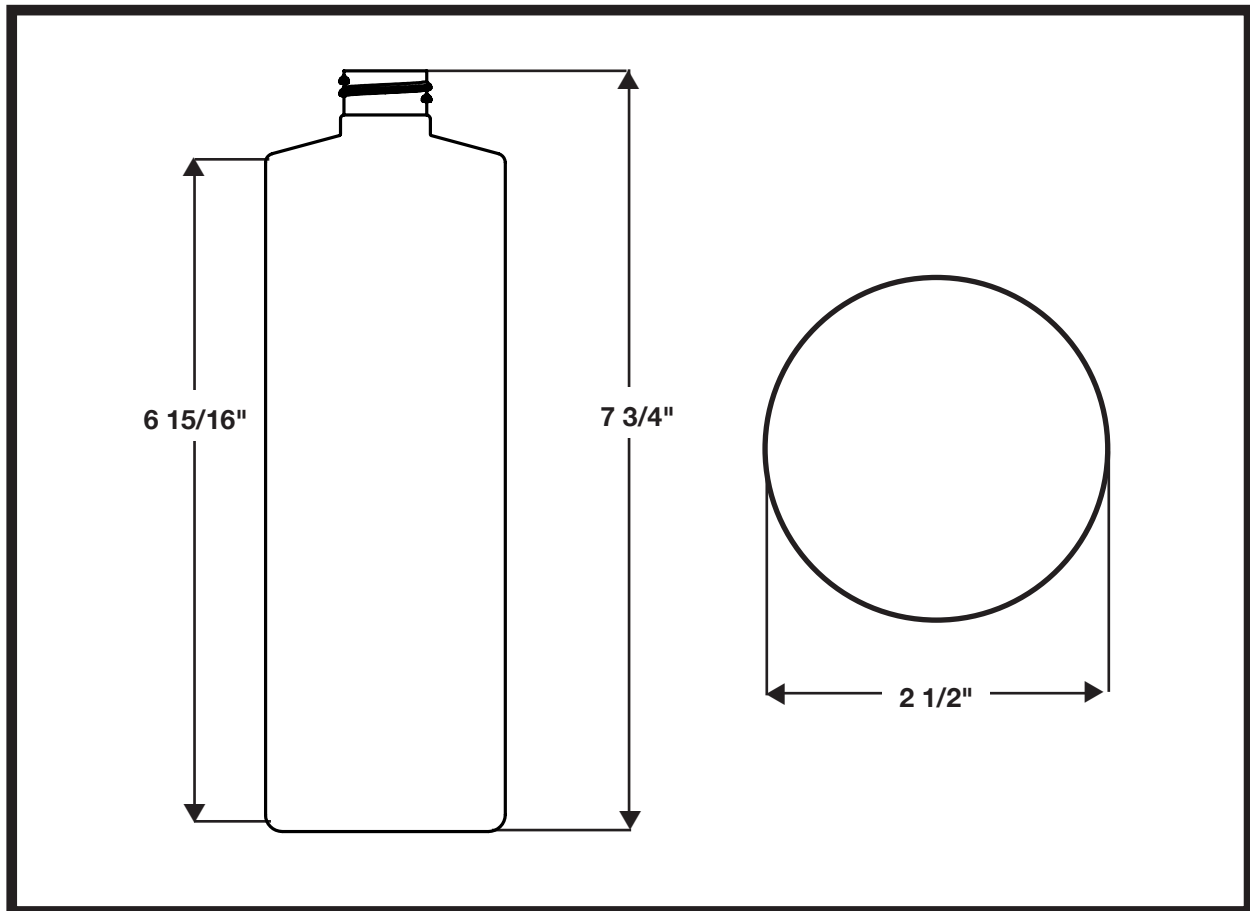

MATERIAL: HDPE

NECK FINISH: 24-410, 28-410

WEIGHT: 30 GRAMS

BOTTLE HEIGHT: 7 3/4"

PANEL HEIGHT: 6 15/16"

DIAMETER: 2 1/2"

CAPACITY: 16 OUNCES



SILKSCREEN DIMENSIONS:

7 1/4" Width x 6 1/4" Height

CASE PACK: 184 Ea.

UNIT PACK: 2,944 Ea.