



PARAGON PACKAGING INC.

1-800-899-1010

WWW.PARAGON-PACKAGING.COM

32 Ounce / 1 Liter Ring Neck Carafe PET

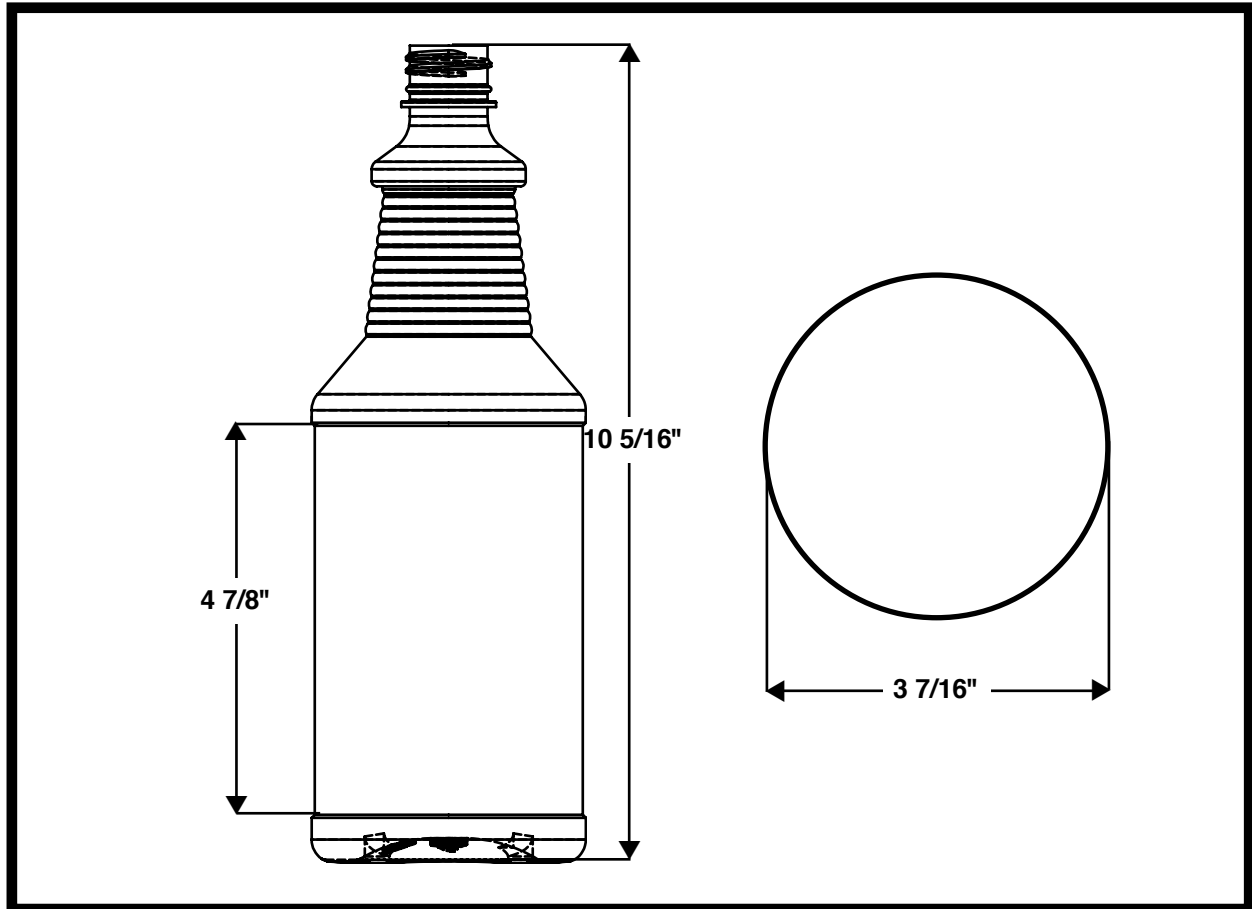

MATERIAL: PET

NECK FINISH: 28-410, 28-400

WEIGHT: 45 GRAMS

BOTTLE HEIGHT: 10 5/16"

BOTTLE PANEL: 4 7/8"

DIAMETER: 3 7/16"

CAPACITY: 32 OUNCES / 1 LITER

SILKSCREEN DIMENSIONS:

4 1/2" Height X 10" Width

CASE PACK: 135 EA.

UNIT PACK: 1,215 EA.
576 EA. 12/1

